User Manual

SBP4K8

Rechargeable lithium ion battery



About this manual

This manual is intended for the SBP4K8, the Sungrow 4.8 kWh battery. This manual does not include all information about the system (i.e. the inverter), just the battery. You can get the additional information about other devices at en.sungrowpower.com or at the webpage of the device manufacturer.

Purpose

This manual provides information about the specification, use, installation, and maintenance of the battery, which is used with the SH series hybrid inverter from Sungrow Power Supply Co., Ltd.

Target group

This manual is targeted for the following audience:

- Qualified personnel. Some tasks that are described in this manual, such as installation, maintenance, assembly and dismantling, should be performed only by qualified personnel, except for simple tasks such as visual inspection.
- End-user. End-users can perform the aforementioned simple tasks, but not those requiring technical expertise.

How to use this manual





Please read this manual and other related documents carefully before using this product, particularly for technical work. Carefully store this manual in a location that is easy to find and ensure that it is available at all times.

The contents of this manual and the use of pictures, logos, symbols, etc. are all owned by Sungrow Power Supply Co. Ltd., with all rights reserved for copyright. No part of the contents of this company may be reproduced without the prior written permission of the company.

Symbols

Important instructions contained in this manual should be followed during installation, operation and maintenance of the battery. Important notes use the following symbols to highlight them.

Table 0-1 Safety and informative document symbols

Symbol	Explanation
	Indicates a hazard with a high level of risk that, if not avoided, will result in death or serious injury.
	Indicates a hazard with a medium level of risk that, if not avoided, could result in death or serious injury.
	Indicates a hazard with a low level of risk that, if not avoided, could result in minor or moderate injury.
NOTICE	Indicates a situation that, if not avoided, could result in equipment or property damage.
	Indicates additional information, emphasized contents or tips that may be helpful, e.g. to help you solve problems or save time.

Abbreviation

BMS: Battery Management System

CAN: Controller Area Network

CC: Constant Current

CP: Constant Power

CV: Constant Voltage

DOD: Depth of Discharge

MCCV: Maximum Charge Current Value

MDCV: Maximum Discharge Current Value

RH: Relative Humidity

SOC: State of Charge

SOH: State of Health

Terms

C-Rate: The term for expressing using current or power. For instance, if the battery's nominal capacity is 94 Ah, 1.0 C discharge means discharging the battery with a current of 94 A.

Contents

About this manual	1
1 Safety instructions	1
1.1 Description of symbols on the battery	1
1.2 Notices for safe use	2
1.3 Emergency situations.....	3
1.3.1 Leaking batteries.....	3
1.3.2 Fire	4
1.3.3 Wet batteries.....	5
1.3.4 Damaged batteries.....	5
1.4 Skills of qualified personnel.....	6
2 Product description	7
2.1 Indicator and ports.....	7
2.2 Dimensions	8
2.3 Nameplate.....	8
2.4 Battery management system (BMS).....	10
3 Transport and storage	11
3.1 Safety handling procedure.....	11
3.2 Transport.....	11
3.2.1 Transporting the battery	11
3.2.2 Inspecting for transport damage	12
3.3 Storage	12
4 Installation process	14
5 Mechanical installation	15
5.1 Delivery contents.....	15
5.2 Selecting the installation location	16
5.3 Installing the battery	16
5.3.1 Free-standing installation.....	17

5.3.2	Wall-mountable installation	19
6	Electrical connection	22
6.1	Grounding	23
6.2	Communication connection	24
6.3	DC connection	26
7	Adding new batteries to an existing system	29
8	Commissioning.....	31
9	Troubleshooting and maintenance	32
9.1	Troubleshooting	32
9.2	Maintenance	33
10	Appendices	34
10.1	Technical data	34
10.2	Active cell balancing	35
10.3	Exclusion of liability	36
10.4	Contact information	37

1 Safety instructions

This section describes the product's safety information. Before proceeding with unloading, unpacking, handling, installation and operation, read and fully understand the following details. Always follow the guidelines.

1.1 Description of symbols on the battery



Please wear safety goggles when working on the battery system.



Electric shock hazard
Serviced by qualified personnel only. Out of reach from children.



Explosive materials



Corrosive substances.
Do not contact eyes, skin or clothes. If you are inadvertently exposed, rinse with water and seek medical attention immediately.



Serious injury may occur due to the heavy weight. Be careful when lifting; bending from the knees and using two people or a mechanical lifting device.



No open flames
Do not expose to flame, incinerate, puncture, or impact



Do not dispose in trash.
Compacting a lithium ion battery is dangerous as it can explode.



Please recycle this lithium ion battery. Do not discard.

1.2 Notices for safe use

Read all safety instructions carefully prior to any work and observe them at all times when working on or with the battery. Failure to observe the precautions described in this section can cause serious injury to persons or damage to property.

General information

DANGER

Risk of explosion

- Do not subject the battery to any strong force.
- Do not mechanically damage the battery (pierce, deform, strip down, etc.)
- Do not heat the battery or dispose of the battery in a fire.
- Do not install the battery in potentially explosive environments.

DANGER

Risk of fire

- Do not expose the battery to temperatures in excess of 45°C.
- Do not place the battery near a heat source, such as direct sunlight, a fireplace, a thermally uninsulated wall exposed to sunlight, hot water, or a heater.
- Keep sources of ignition such as sparks, flames, and smoking materials away from the battery.

DANGER

Risk of electric shock

- Do not disassemble the battery.
- Do not handle a wet battery or use wet tools.
- Do not soak the battery in water or expose it to moisture or liquids.
- Keep the battery away from children and animals.
- Wear suitable clothing, guards and gloves to prevent you from direct contact with the DC voltage.
- Use insulated tools during working with battery.
- Set aside metal jewelry before working on the DC circuit.

Battery handling information

NOTICE

Comply with local standards for use with the battery.

Any man-made damage will void the limited warranty for the battery. Handle the battery with care to protect it from damage.

- Use the battery only as intended and designed.
- The battery must only be installed at a suitable location.
- Ground the battery completely before use.
- Do not use the battery if it is defective, appears cracked, broken or damaged, or fails to operate.
- Do not use the battery SBP4K8 together with other types of batteries.
- Do not pull, drag or step on the battery.
- Do not leave any foreign objects inside the battery.
- Do not repair or modify the battery. It is not user serviceable.
- Do not pull out any cables when the battery is powered on.
- Do not damage the sheath of cables, wire harness and connectors.
- While the battery is charged, used and stored, keep it away from materials that are prone to electric discharge, including static discharge.
- Keep the battery away from babies and children to avoid any accidents. If younger children use the battery, their guardians should explain the proper handling method and precaution before using.
- Cover terminals with insulating tape before proper disposal.

1.3 Emergency situations

1.3.1 Leaking batteries

Abuse/misuse/damage of the battery may cause increasing of internal pressure in the battery cells. It may result in the electrolyte venting. In the event that battery electrolyte is released:

- Do not enter the room under any circumstance.
- Avoid contact with the leaking liquid or gas.

If one is exposed to the leaking substance, follow the suggestions below to minimize the chance of injury:

- Inhalation: Evacuate the contaminated area, and seek medical aid.
- Eye contact: Rinse eyes with large amounts of water using emergency eye wash bottle for at least 15 minutes, and seek medical aid immediately.
- Skin contact: Wash the affected area thoroughly with plenty of water for at least 15 minutes. If possible, remove or saturate contaminated clothing with water. Seek medical aid if the patient is distressed.
- Ingestion: Induce vomiting, and seek medical aid immediately.

Wipe out the contacted area with a sponge or cloth that is soaked in water until you obtain medical aid. These materials can damage skin and eyes, causing blindness.

1.3.2 Fire

Fire may occur with the battery despite its careful design. Likewise, a fire near the battery can cause it to catch fire.

Protective equipment

A respirator is not required during normal operations.

In the event of a fire, hazardous fumes including carbon monoxide, carbon dioxide, and/or various hydrocarbons may be emitted. To comply with the Personal Protective Equipment Directive (89/686/EEC), use a full-face self-contained breathing apparatus (SCBA) with full protective gear during fire fighting.

Fire fighting

NOTICE

- **In the event of a fire, only qualified firefighters with appropriate protective equipment are permitted to enter the room where the battery is located.**
- **Battery fires can take up to 24 hours to fully extinguish. Consider allowing the system to burn. Smoke indicates that the battery is still burning. Always note that there is a risk of the battery re-igniting.**

Proceed as follows for firefighting.

1. Shut off any connected power system or electronics such as the battery, battery isolator, PV DC isolator(s), AC isolator, solar supply main switch and normal supply main switch.

2. Perform an adequate knock down on the fire before entering the incident's hot zone.
3. If the battery catches on fire, use an FM-200 or CO2 extinguisher to extinguish fire.
4. If the battery becomes involved in fire or is bent, damaged or breached in any way, or if suspect that the battery is heating, use large amounts of water to cool the battery. Do not try to extinguish the fire with a small amount of water. Always obtain an additional water supply.
5. If the fire is not from the battery and has not spread to it yet, use an ABC fire extinguisher to extinguish the fire. Remove batteries and other ignition sources from the scene of a fire

1.3.3 Wet batteries

If the battery is wet, do not let people access it, and then contact Sungrow or an authorized service partner for technical support.

If a battery is submerged in water or flooded, first, switch off all circuit breakers in the system to cut off the power supply to the battery. Wait until floodwaters subside and do not approach near battery. If someone needs to go into the flooded water, wear insulated full length rubber boots and gloves.

Do not use a flooded battery again.

1.3.4 Damaged batteries

The battery consists of lithium ion cells. These are considered dry cell batteries. If damaged, only a small amount of battery fluid can leak.

A damaged battery can cause rapid heating of the battery cells. If you notice smoke coming from the battery area, assume that the battery is burning and take appropriate action as described in "**Fire fighting**".

Damaged batteries are dangerous and must be handled with extreme caution. They are not fit for use and may pose a danger to people or property. If a battery seems to be damaged:

1. Pack it in its original container.
2. Store it in a separated room like the installation place.
3. Contact Sungrow at +61 1800 786476 (Sungrow) in Australia or an authorized service partner.

DANGER

A damaged battery may release dangerous material and a flammable gas mixture. Never try to repair the battery even if you are qualified electrician.

1.4 Skills of qualified personnel

The battery must only be installed and commissioning by qualified personnel. Qualified personnel must have the following skills:

- training in the installation and commissioning of the solar PV hybrid systems, as well as knowledge of how to deal with hazards;
- knowledge of the manual and all further applicable documents; and
- knowledge of local applicable standards and guidelines.

2 Product description

The battery SBP4K8 is designed for residential energy storage systems. The inbuilt battery management system (BMS) monitors its operation and prevents the battery from operating beyond the specified limitations.

The battery can be expanded to 3 units in parallel at most.

NOTICE

The battery can only be used with the Sungrow SH series hybrid inverters. Otherwise it cannot work normally.

Any other or additional usage is not permitted except the intended use.

2.1 Indicator and ports

The following figure shows the ports and indicator of the battery.

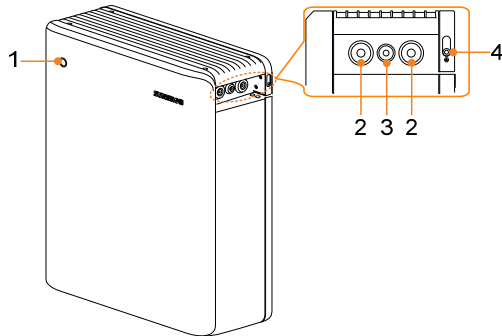



Figure 2-1 Ports and indicator

Table 2-1 Designations on the battery

Item	Designation	Definition
1	LED indicator	Green, red or orange can be indicated, from which user can identify the current state. For details, see Table 2-2 .
2	+/-	Inlet and outlet for the power cables.
3	Com.	Inlet and outlet for the communication cable.

Item	Designation	Definition
4		Grounding position.

The following table describes the definitions of the LED indicator.

Table 2-2 Descriptions of the LED indicator states

Color	State	Definition
Green	On	Normal operation state.
	Blinking slowly (1s on and 2s off)	Standby state
	Blinking quickly (0.2s on and 0.2s off)	Starting state.
Red	On	Fault state.
Orange	Blinking	Upgrading state.
Off	-	The battery is not powered on.

2.2 Dimensions

Figure 2-2 shows the dimensions of the battery: 565 mm high by 510 mm wide by 190 mm deep.

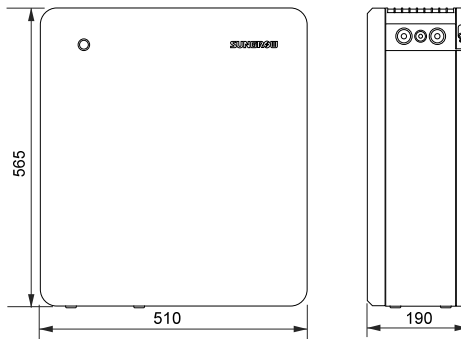

Figure 2-2 Dimensions (unit: mm)

2.3 Nameplate

The nameplate attached on the side of the battery can be used to uniquely identify the battery. The information on the nameplate is required for safe use and for device identification with service matters.

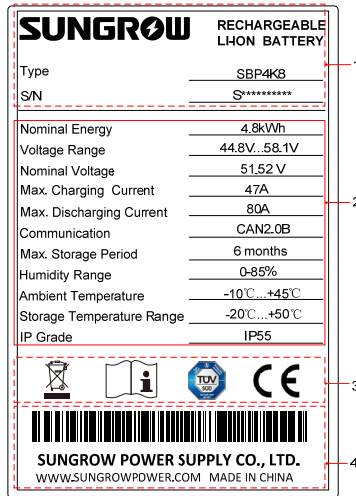

Figure 2-3 Nameplate on the battery

* The image shown here is for reference only. The actual product that you receive may be different.

Item	Description
1	Sungrow logo and product type.
2	Technical data.
3	See Table 2-3 .
4	Barcode, company name, website and origin.

Table 2-3 Icon descriptions

Icon	Description
	Do not dispose of the battery together with household wastes. For Australian customers, please contact Sungrow or a battery recycler.
	Read the user manual before any operation of the device.
	TUV mark of conformity.
	CE mark of conformity.

2.4 Battery management system (BMS)

The battery consists of 14 long-lifetime Samsung SDI prismatic battery cells and a battery management system (BMS). The BMS is used to ensure the safe and efficient operation of the battery. This objective is achieved by the collaboration of the key BMS functions, including:

- BMS state control;
- battery cell/pack monitoring (voltage, current and temperature);
- battery status estimation (SOC and SOH);
- battery charge/discharge control (MCCV and MDCV estimation);
- active cell balancing (see Appendix **10.2**);
- external communication (CAN 2.0 B communication with the SH series hybrid inverter and other modules, see section **6.2** for details. The BMS uploads the information to the SH series hybrid inverter through CAN communication. End-users can require the relevant information of the battery through the inverter LCD screen or the app.);
- safety and multi-level protections at cell level and battery system level;
- parallel operation control; and
- local and remote easy firmware upgrade.

3 Transport and storage

3.1 Safety handling procedure

Quarantine

Packages that are crushed, punctured or torn open to reveal contents should not be transported. Such packages should be isolated until the shipper has been consulted, provided instructions and, if appropriate, arranged to have the product inspected and repacked.

Spilled product

In the event that damage to packaging results in the release of cells or batteries, the spilled products should be promptly collected and segregated and the shipper should be contacted for instructions.

Environmental misusage

- Do not leave the battery near a fire or allow it to be in a location that is in contact or open to other heat sources, such as direct sunlight, hot water systems, heat pumps, gas heaters and walls that are thermally uninsulated from the sun. This also implies not to incinerate the battery or allow it to be in contact with any flame.
- Do not throw the battery into the fire.
- Do not immerse, throw, or wet the battery in water/seawater or any other liquid.

3.2 Transport

3.2.1 Transporting the battery

Lithium ion batteries are hazardous goods. Therefore the following points must be observed when transporting the battery:

- Observe the general transport regulations based on the mode of transport as well as all legal regulations.
- Consult an external hazardous goods expert.

The battery data relevant for transport is provided in the following:

- hazardous goods class: 9;
- UN number: UN3480 'lithium-ion batteries'; and
- battery mass (including packaging): less than 55 kg.

3.2.2 Inspecting for transport damage

The battery is thoroughly tested and inspected before delivery. Although sturdy packaging is used, damage may still occur during shipping. Unpack the packaging immediately after transport and inspect the contents for transport damage.

1. Check whether there is visible damage to the packaging.
2. Check whether there is external damage to the product.
3. Check the completeness of delivery contents according to the packaging list or as listed in section 5.1.
4. Check the information on the nameplate to get the serial number.

If damage (deformation, damage to the housing, or similar) is discovered, do not use the battery under any circumstance. Make a descriptive notation on the delivery receipt before signing. Contact Sungrow or a Sungrow representative or partner.

Keep the original packaging for future storage or transportation.

3.3 Storage

If you do not install the battery immediately, or if the battery is removed from operation and needs to be stored for a long period, please choose an appropriate location to store it. Instructions for storage are:

- Do not stack more than four battery boxes.
- The temperature must be in the range of -20°C to 50°C.
- The humidity must be less than 85 % RH, non-condensing.

The battery box should be upright as shown in the following figure. Do not stack upside down when storing the battery box.

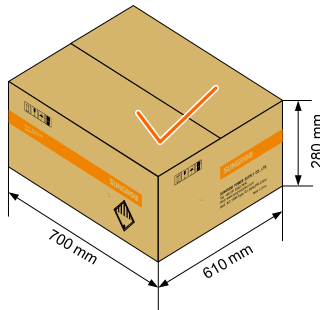

Figure 3-1 Correct storage

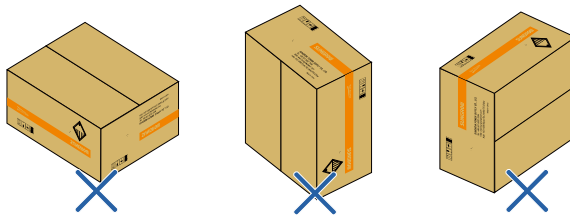

Figure 3-2 Wrong storage

When the battery is not connected to the SH series hybrid inverter, the battery cannot be automatically charged. The battery will automatically discharge at a minimum rate during storage. Capacity degradation will occur depending on storage time. For this reason, observe the following points:

- It is recommended that the battery is charged to approx. 40 % of the nominal capacity (which is the state of charge upon delivery) when stored.
- To minimize capacity degradation, the storage temperature should be controlled at 25°C.
- Do not store the battery for longer than 6 months.
- Connect the battery to the SH series hybrid inverter in 6 months and commission the system.

NOTICE

Damage/destruction of the battery is likely to occur due to deeply discharging beyond the maximum DOD when in long-term storage.

4 Installation process

Install the battery according to the following flow chart. For a detailed reference, see **Table 4-1**.

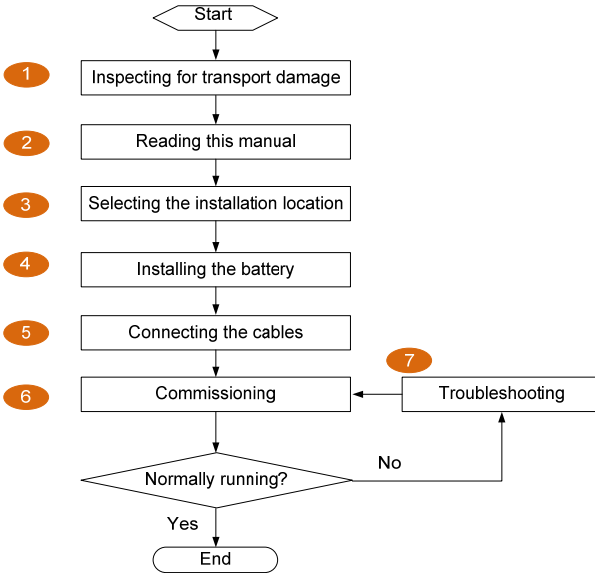

Figure 4-1 Installation flow chart

Table 4-1 Explanation for the flow chart

Order	Explanation	Reference
1	Unpacking and inspecting the delivery.	3.2.2 and 5.1
2	Reading the manual, especially the safety instructions.	1
3	Selecting an optimal installation location.	5.2
4	Free-standing installation or wall-mountable installation.	5.3.1 or 5.3.2
5	Grounding, communication, DC power connection and if applicable, connection of multiple batteries.	6 and 7
6	Commissioning the whole system.	8 7
7	Troubleshooting.	9

5 Mechanical installation

5.1 Delivery contents

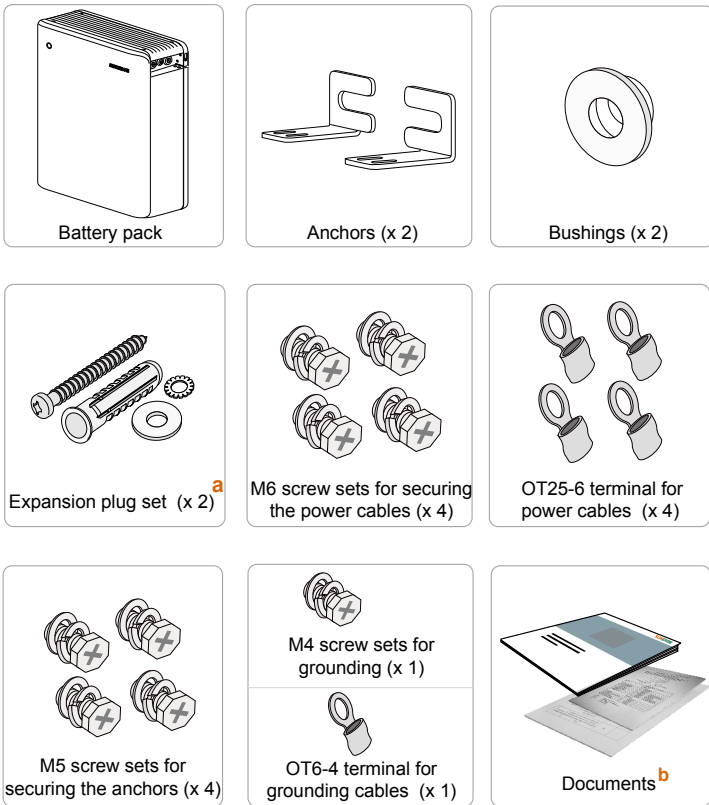

Figure 5-1 Delivery contents

Note a: each set includes a self-tapping screw, a spring washer, a fender washer, and an expansion tube.

Note b: the documents include this user manual, a packaging list and a product test report.

5.2 Selecting the installation location

Incorrect installation location may cause damage to the battery. The optimal location should meet the following requirements:

- Follow the local applicable standards and guidelines.
- The ambient temperature should be always in the range of -10°C to +45°C, and the humidity is less than 85 % RH under no condensing.
- No flammable or explosive materials around the area.
- The place should be convenient for the installation, cable connection and service, and with good ventilation.
- Flat and level floor for free-standing installation.
- For installation outdoors, it is recommended to select a shaded side of the building under eaves or other shelter to prevent the battery from exposure to direct sunlight, rain, and snow.
- The wall or floor should be able to hold the load of the battery (at least 150 kg).
- Observe the minimum clearances specified in the local standard (where applicable), e.g. for sufficient heat dissipation with natural ventilation, and for maintenance work.

NOTICE

The battery will stop running to protect itself if the ambient temperature is beyond the allowable range. Frequent exposure to harsh temperatures will deteriorate the performance and life of the battery.

5.3 Installing the battery

The battery with an IP55 rating can be installed indoors or outdoors. It supports free-standing installation and wall-mountable installation.

The bracket and expansion bolt sets for wall-mountable installation will be delivered separately if requested.

The positioning template is part of the delivery scope and is used for convenience for marking the positions to drill holes.

DANGER

In order to avoid electrical shock or other injury or damage, call an appropriate authority or inspect if there is electricity, plumbing or gas installations before drilling holes.

5.3.1 Free-standing installation

It is recommended to secure the battery to the wall after locating for safety. Proceed as follows to install the anchors to both sides of the battery.

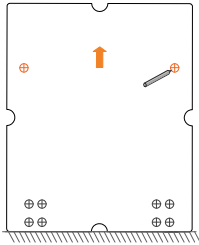

1. Mark two holes using the positioning template.

Note:

- 1) The lower edge of the template should be against the floor.
- 2) The arrow should point upwards.

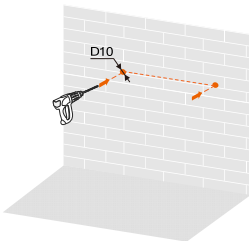

2. Drill two holes of 10 mm diameter to suit the provided M6 expansion bolts in the wall. The drilling depth should be at least 70 mm.

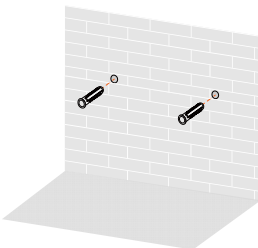

3. Drive the expansion bolts into the holes.

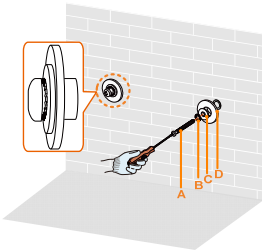

4. Use the expansion bolt sets to install the bushings.

Be sure to adhere to the following sequence as shown on the left:

- self-tapping screw
- spring washer
- fender washer
- bushing

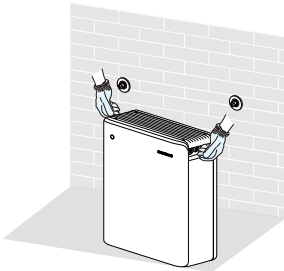

5. Move the battery with the help of other people. Hold both sides of the top cover to move it to the installation place. Align the slots on the back of the battery with the bushings perfectly.

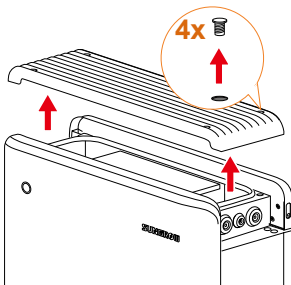

6. Unscrew four M5 screws and remove the top cover

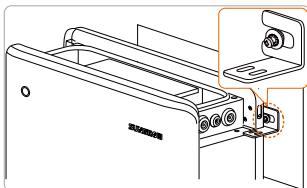

7. Install the anchors to each side, with the slot through the bushing.

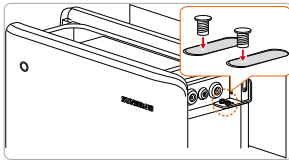

- Use the provided M5 screws to secure the anchors to the battery with a torque of 3.0 N·m.

5.3.2 Wall-mountable installation

A wall-mounting bracket and four expansion plug sets will be additionally delivered for wall-mountable installation, as shown in the **Figure 5-2**.

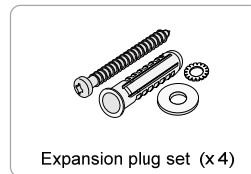
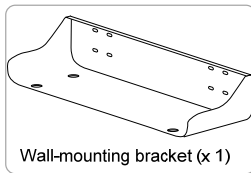
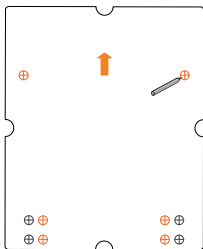

Figure 5-2 Wall-mounting accessories

Proceed as follows to install the battery to the wall.



- Mark six holes with the template.

Note:

- The template should be vertically placed.
- The arrow should point upwards.
- Select 4 holes for the wall-mounting bracket; 1 hole in a row for each side.

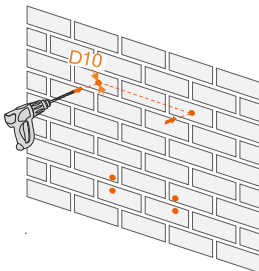

- Drill six holes of 10 mm diameter to suit the provided M6 expansion bolts in the wall. The drilling depth should be at least 70 mm.

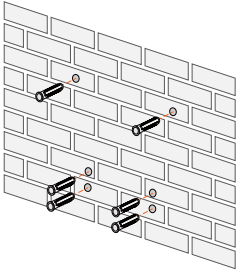

3. Drive the expansion bolts into the holes.

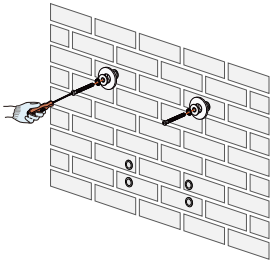

4. Install the bushings for the anchors.
Be sure to adhere to the following sequence (as described in the free-standing installation procedure): self-tapping screw, spring washer, fender washer and bushing.

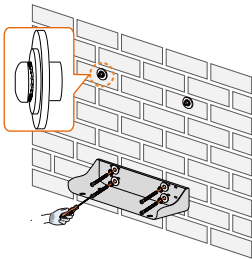

5. Install the wall-mounting bracket.
 - 1) Be sure to adhere to the sequence (as described previously): self-tapping screw, spring washer, fender washer and bracket.
 - 2) Tighten the self-tapping screws to a torque of 6.0 N·m.

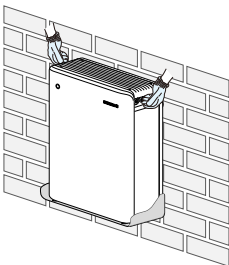

6. Hold both sides of the top cover to put the battery to the bracket, with the four bumps on the bottom aligned into the holes.

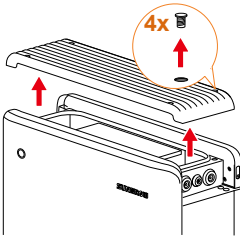

7. Unscrew four M5 screws and remove the top cover

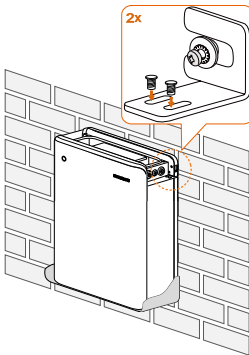

8. Install the anchors to each side, with the slot through the bushing. Use the provided M5 screws to secure the anchors to the battery with a torque of 3.0 N·m.

6 Electrical connection

WARNING

Make sure that the SH series hybrid inverter is switched off before connecting the battery to the inverter.

The following figure shows the cable connection between the battery and the SH series hybrid inverter.

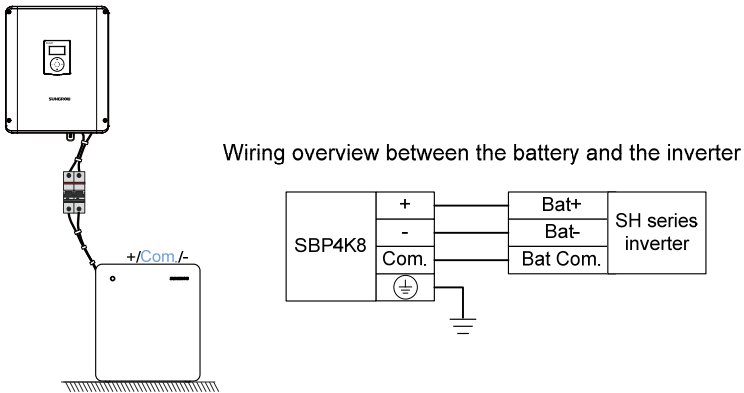

Figure 6-1 Wiring between the battery and the inverter

The following figure shows the cable connection between the parallel batteries.

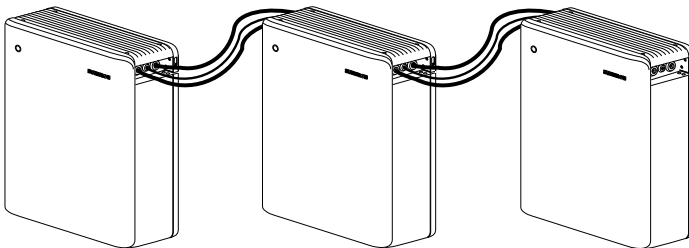

Figure 6-2 Battery connection in parallel

6.1 Grounding

There is one point for grounding on each side of the battery. Select either one to ground the battery according to the relevant regulations. The cross-section area of the grounding copper conductor should be larger than 6 mm^2 .

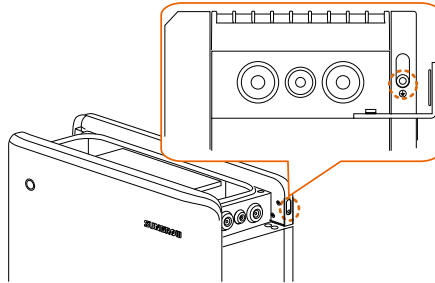

Figure 6-3 Battery grounding port

Proceed as follows to ground the battery.

1. Take out the M4 OT terminals and M4 screws from the packaging.
2. Use the screw set with washers to tighten the terminal lug firmly with a torque of $1.6 \text{ N}\cdot\text{m}$ for reliable grounding.

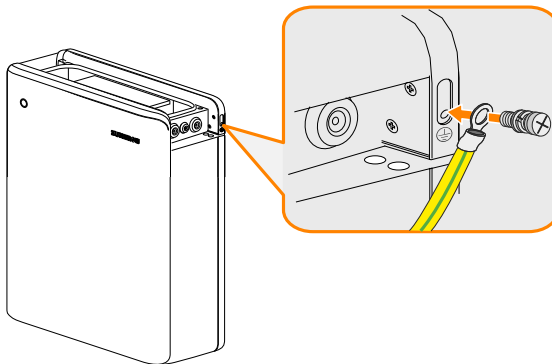

Figure 6-4 Connecting the protective earth cable

3. Tighten the other end of the grounding wire to the grounding point.
4. Optional: if there is more than one battery, connect the protective earth cable between the adjacent modules to realize equal potential.

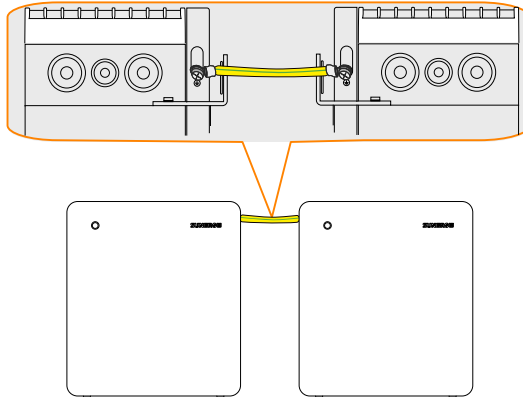
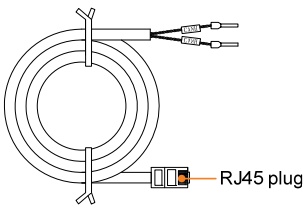

Figure 6-5 Grounding connection between multiple batteries

6.2 Communication connection

The CAN communication cable is delivered with the SH series inverter. The RJ45 plug on one end is used to connect the battery. The CANH and CANL plugs on the other end connect to the corresponding, eponymous terminals inside the inverter.

Proceed as follows to connect the RJ45 communication cable to the SBP4K8 and the SH series hybrid inverter.



1. Take out the CAN cable from the packaging (the cable on the left is delivered with the SH series hybrid inverter).

Users can also prepare a standard Ethernet cable without the RJ45 plug (as in step 3) or use a cable with plugs.

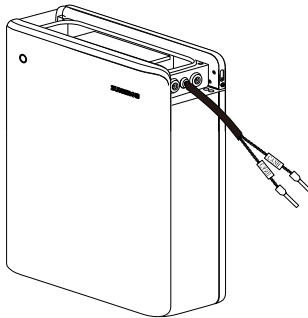

2. Use a sharp object to puncture the **com.** grommet.
3. Lead the CANH and CANL plugs from inside out through the **com.** port. This will result in the cable with the RJ45 plug on the inside end of the **com.** socket, and the CANH and CANL plugs on the outside of the battery, to plug in to the inverter.

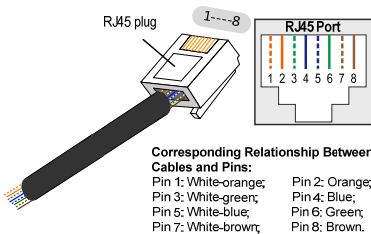

4. (optional alternative) If cutting the supplied RJ45 plug before inserting it into the **com.** port (after the grommet is punctured), or using an Ethernet patch cable (without a plug on it), use the Ethernet wire stripper to strip off 8 mm–15 mm from the protective layer. Use the Ethernet crimper to crimp the cable and connect the cable to the RJ45 plug according to TIA/EIA 568B.

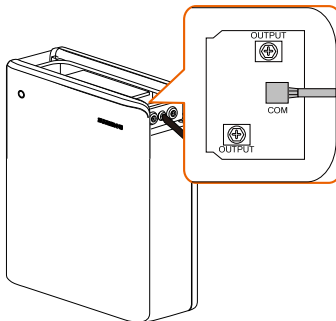

5. Insert the RJ45 plug into the **com.** port until it makes a clicking sound. Pull the cable outwards gently to confirm whether it is fastened firmly.

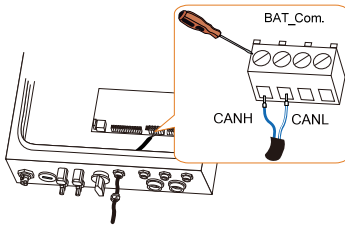

6. Thread the end of the cable with the CANH and CANL plugs through one of the **com.** ports in the bottom of the inverter.
7. Connect the CANH and CANL plugs to the corresponding, eponymous screw terminals inside the SH series hybrid inverter.

* The cable supplied with the inverter has blue and green wires for CANH and blue-white and green-white wires for CANL. If using a different cable then you can use blue for CANH and blue-white for CANL.

8. **(Optional)** If there is more than one battery, connect the communication cable between the adjacent batteries. If needed, refer to **step 4** to add the RJ45 plug to a standard Ethernet cable for parallel communication connection.

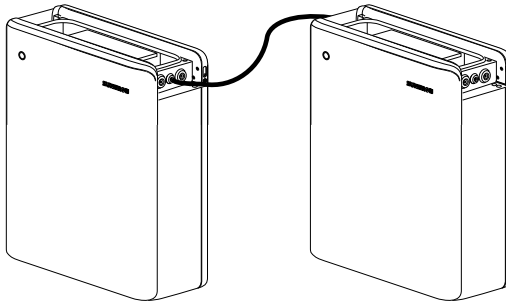

Figure 6-6 CAN connection between multiple batteries

6.3 DC connection

Incorrect connection may damage the device. Connect the DC cables strictly in accordance with the description in the manual.

⚠ DANGER

Risk of electric shock. Death or serious injuries.

- Ensure that the battery is powered off before connection.
- Use safety tools to ensure a safe DC connection.

NOTICE

The resistance of DC cables will lower the battery voltage. It is recommended that the DC cable between the battery and the SH series hybrid inverter is less than 3 m.

The DC cables should be close to each other. Lay the cables in a protection pipe or tie them with cable ties.

A two-pole DC circuit breaker with over-voltage and over-current protection (100 V DC and 100 A DC) should be installed between the SH series hybrid inverter and the battery.

Proceed as follows to connect the power cables, with a cross-section of 16 mm²–25 mm², OT25-6 lugs and a cable diameter of 13 mm–16 mm.

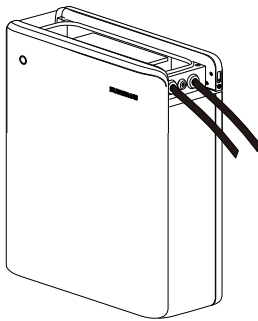

1. Switch off the DC circuit breaker between the SH series hybrid inverter and the battery and secure it against reconnection.
2. Use a sharp object to puncture the "+" and "-" grommets and lead the cable through it, as shown in the following figure.

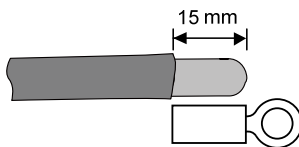

3. Strip the cable jacket by 15 mm.

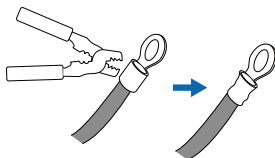

4. Crimp the OT terminal and install the heat shrinkable casing, as shown below.

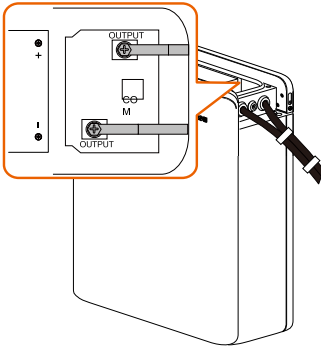

5. Connect the positive cable to the positive "+" terminal and the negative cable to the negative "-" terminal. Tighten the screws to a torque of 2.8 N·m. Be sure not to connect the negative cable to the positive "+" terminal and the positive cable to the negative "-" terminal, as this may damage the inverter.

6. Lay the cables in a protection pipe or tie them with cable ties.
7. Connect the other end of the positive cable to the **Bat+** port and the negative cable to the **Bat-** port at the bottom of the SH series hybrid inverter.
8. **(Optional)** If there is more than one battery, connect the power cable between the adjacent batteries.

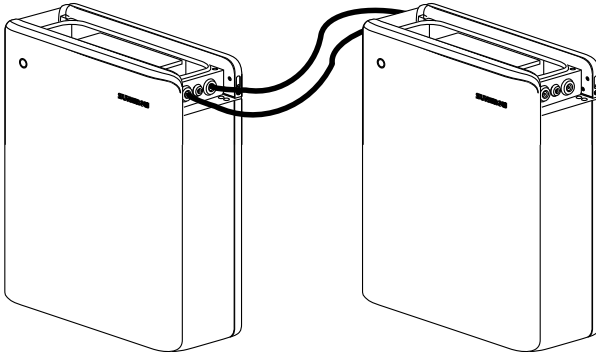

Figure 6-7 DC connection between multiple batteries

NOTICE

The DC cable between parallel batteries should be less than 0.5 m. Otherwise it will void the limited warranty for the battery.

For connecting multiple batteries in parallel, the DC cables should be as short as possible, otherwise the lifetime of the battery may be affected.

7 Adding new batteries to an existing system

The battery capacity can be increased by adding a battery. There should be at most two additional batteries.

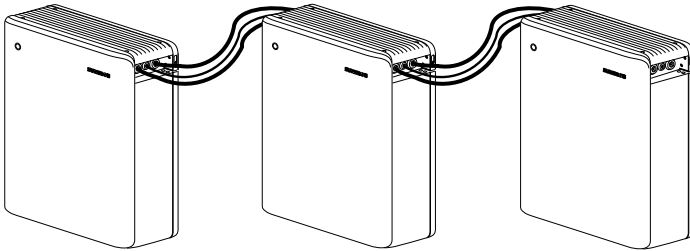

Figure 7-1 Battery connection in parallel

NOTICE

When using old and new batteries together, the usable capacity will be less than the sum of the actual capacity of the old and new batteries.

The DC cable between parallel batteries should be less than 0.5 m. Otherwise it will void the limited warranty for the battery.

For connecting multiple batteries in parallel, the DC cables should be as short as possible, otherwise the lifetime of the battery may be affected.

Proceed as follows to connect an additional battery to the inverter-connected battery.

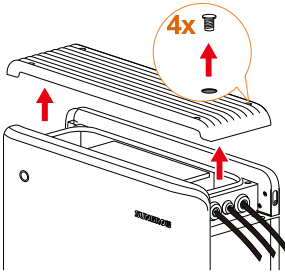

1. Unscrew four M5 screws and remove the top cover from the inverter-connected battery.

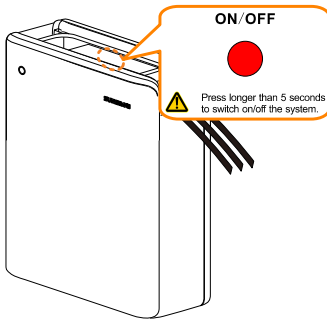

2. Press the button longer than 5 s to switch off the battery.

3. Switch off the DC circuit breaker between the SH series hybrid inverter and the battery and lock it to prevent reconnection.
4. Connect the protective earth cable, communication cable and DC cables for the new battery as described previously.

8 Commissioning

Proceed as follows to put the battery in operation for the first time.

1. Switch on the AC circuit breaker next to the SH series hybrid inverter.
2. Switch on the DC circuit breaker between the SH series hybrid inverter and the battery.
3. Press the **"ON/OFF"** button on the top of the battery and check the status of the indicator on the front. It will change from flashing green slowly to flashing green quickly, and finally steady green. See Table 8-1. Each state means standby, startup and running, respectively. If the indicator stays red, check the inverter error code and measure the voltage and check how that corresponds with the battery voltage under "Run Info" on the inverter LCD. For more details on troubleshooting, see section **"9.1 Troubleshooting"**.
 - For a new system with multiple batteries in parallel, you just need to press the **"ON/OFF"** button on any battery. When its indicator becomes green, the other batteries will then start.
 - If you expand an existing system with new batteries, when the voltage difference between two parallel batteries is larger than 0.7 V, the indicator of the expanded battery will continue to blink green slowly. However, this is normal and the expanded batteries will normally run with the indicator green after a charge and discharge cycle at most for the energy storage system.
4. Reinstall the top cover and tighten the M5 screws to a torque of 3.0 N·m.

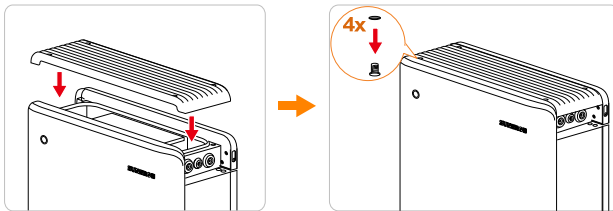

5. Rotate the external DC switch which is connected to the PV system to "ON". Set the battery type via the LCD menu of the SH series hybrid inverter by changing to off, then go to settings with the password 111.

The battery will communicate with the SH series hybrid inverter via CAN communication. For details, see section **6.2** or the SH series hybrid inverter user manual.

9 Troubleshooting and maintenance

9.1 Troubleshooting

Check the status of the indicator on the front of the battery to determine in what state the battery is.

When the battery falls beyond the prescribed range, it goes into fault state with the indicator turning red. The battery's BMS periodically reports its operational state to the SH series hybrid inverter. When an error is reported, the inverter will show the error code on the display. The abnormal state will be released when the battery recovers its normal condition.

The possible error messages are as follows:

- Battery over-voltage
- Battery under-voltage
- Battery over-temperature
- Battery under- temperature
- Battery discharge over-current
- Battery charge over-current
- ID competing failure
- Cable connection failure

For the detailed error codes and troubleshooting, see the user manual for the SH series hybrid inverter. Contact Sungrow or an authorized service partner if unsure about how to fix the issue.

The follow table lists some frequently asked questions.

Error Description	Troubleshooting
Error 703 on the inverter LCD indicates that there is a battery average under-voltage.	<ol style="list-style-type: none"> Restart the battery and inverter, waiting for 30 s before turning them back on to let the inverter's capacitors discharge. Check the battery voltage ("Bat. Vtg" under "Run Info" menu on the LCD). Measure the battery voltage to see how this compares with the LCD reading. If applicable for the associated above faults, check the temperature, current and test for continuity.
Error 714 on the inverter LCD indicates that there is no communication between the battery and the inverter.	<ol style="list-style-type: none"> Refer to section 6.2 for details on how to do the connection. If error 703 and error 714 occur, fix error 714 first, as it may then clear error 703.
The battery is not discharging.	<p>On the inverter settings with the password 111, make sure about the following items and then restart the battery.</p> <ol style="list-style-type: none"> The battery type is set correctly. The battery usage time is all the time by default. Whether there is any export limitation. The backup SOC under off-grid is set to 0 %.
The battery is not charging.	<ol style="list-style-type: none"> Make sure there is enough excess PV power after going to the loads. Check the inverter LCD if there is any error with the battery or the inverter. Refer to the inverter user manual for the troubleshooting. Check the MCCV value under "Run Info" menu on the inverter LCD If the error persists, Contact Sungrow for a solution.

9.2 Maintenance

Integrated with a self-test function, the battery will report the relevant status information when the protection function is activated.

Contact Sungrow or a service partner when you find any damage to the battery.

Clean the exterior of the battery with a dry cloth. Use of solvents, abrasives or corrosive materials for cleaning is prohibited.

Do not dispose of the battery. For Australian customers, please contact Sungrow or a battery recycler.

10 Appendices

10.1 Technical data

Parameter	Specification
Total energy	4.8 kWh
Battery capacity	94 Ah
Nominal voltage	51.52 V
Battery type	Lithium ion
Voltage range	44.8 V–58.1 V
Max. charge current	47 A
Max. discharge current	80 A
Round-trip efficiency (RTE)	> 95 %
Depth of discharge (DOD)	> 95 %
Cell balance technique	Bi-directional active cell balancing
Cell balance current	5 A
Scalability	Yes, up to 14.4 kWh
Over/under voltage protection	Yes
Over current protection	Yes
Over/under temperature protection	Yes
Short-circuit protection	Yes
Mounting type	Free-standing / wall-mountable
Communication	CAN
Firmware upgrade	Local and remote
Current consumption in sleep mode	< 30 μ A
Noise	< 30 dB
Rating for protection from solids and liquids	IP55
Relative humidity range	0–85 %, non-condensing
Operating ambient temperature	-10°C to 45°C
Storage temperature	-20°C to 50°C
Altitude	< 2000 m
Storage period	Less than 6 months
Cooling strategy	Natural convection
Weight	48 kg
Dimensions (W x H x D)	510 mm x 565 mm x 190 mm
Certifications	UN38.3, IEC62619, IEC-61000-6-1/3

10.2 Active cell balancing

Without cell balancing, the cells in the battery are charged unevenly. This can cause some cells to overcharge while others are not fully charged, as shown in **Figure 10-1**. Also, some cells are not fully discharged to the maximum allowable depth of discharge (DOD), as shown in **Figure 10-2**. With passive cell balancing, resistors are used for each cell to prevent overcharging, which wastefully dissipates energy as heat. With active cell balancing, the charge is distributed evenly across cells, allowing each cell to be fully charged and discharged to the maximum allowable DOD, as shown in **Figure 10-3** and **Figure 10-4**.

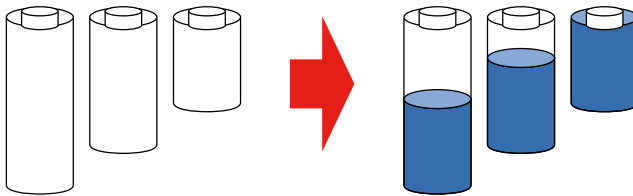

Figure 10-1 Not fully charged

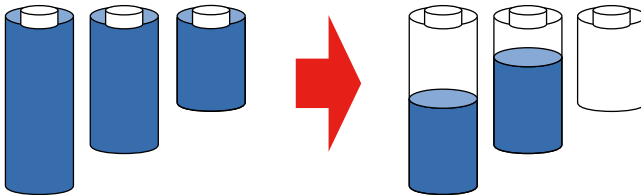

Figure 10-2 Not fully discharged (wasted capacity)

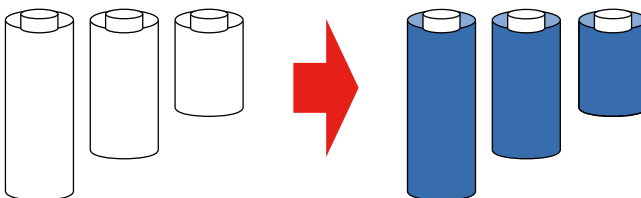

Figure 10-3 Charge redistributed among cells

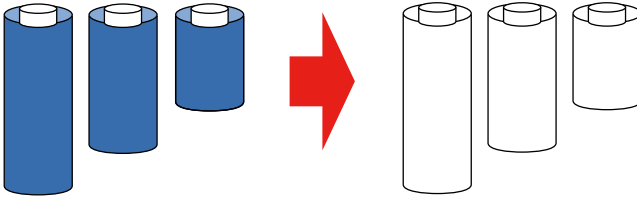

Figure 10-4 Full capacity utilization

10.3 Exclusion of liability

The contents of the manual may be periodically updated or revised, and is subject to change without notice. The latest manual can be acquired via en.sungrowpower.com.

Guarantee or liability claims for damage of any kind are excluded if they are caused by one or more of the following:

- inappropriate use or installation of the products;
- installing or operating the products in an unintended environment;
- ignoring relevant safety regulations in the deployment location when installing or operating the products;
- ignoring safety warnings and instructions contained in all documents relevant to the products;
- installing or operating the products under incorrect safety or protection conditions;
- altering the products or supplied software without authority;
- the product faults due to operating attached or neighboring devices beyond allowed limit values; and
- damage caused by the natural environment beyond the rated operating range of the SH series hybrid inverter.

10.4 Contact information

Should you have any problems, please contact us through the following information. We will be more than happy to assist you!

Company: Sungrow Power Supply Co., Ltd.
Website: en.sungrowpower.com
Email: info@sungrow.cn, service@sungrow.cn
Address: No. 1699 Xiyou Rd., New & High Technology Industrial Development Zone, Hefei, P. R. China.
Zip: 230088
Telephone: +86 551 6532 7834, +86 551 6532 7845
Fax: +86 551 6532 7856

Here is a link to more contact information, which includes for other offices around the world: <http://en.sungrowpower.com/contact/>.

Australia contact information:

Company: Sungrow Australia Group Pty. Ltd.
Email: info@sungrowpower.com.au,
service@sungrowpower.com.au
Address: Suite 1703, 99 Mount St, North Sydney NSW 2060
Telephone (Toll free): 1800 SUNGROW (786 476)
Tel (Overseas): +61 2 9922 1522